



SERDI

MICRO magnet

Multi-angle seat cutting unit with precision dual centering air cushion system. Ideal for low volume motorcycle and for automotive shops on small diameters.

MICRO magnet

User friendly ergonomic design.

Easy tool setting, multi-angle seat machining and seat pocket counterboring.

Uses original SERDI tooling for machining accuracy and economical upgrade to bigger equipment.

Machining capacity from 0.63" / 16 mm to 2" / 50 mm.

Direct magnetic clamping on head center's steel plate.

Rugged and heavy construction: 15.4 lb / 7 kg) for rigidity, durability and dependability.

Precision Vernier for consistent cutting depth control. 0.600" / 15 mm total travel, 0.0008" / 0.02 mm increments.

8 degrees spindle tilt accommodate canted and compound angle valves.

Dual plane and spherical air cushions for perfect concentricity

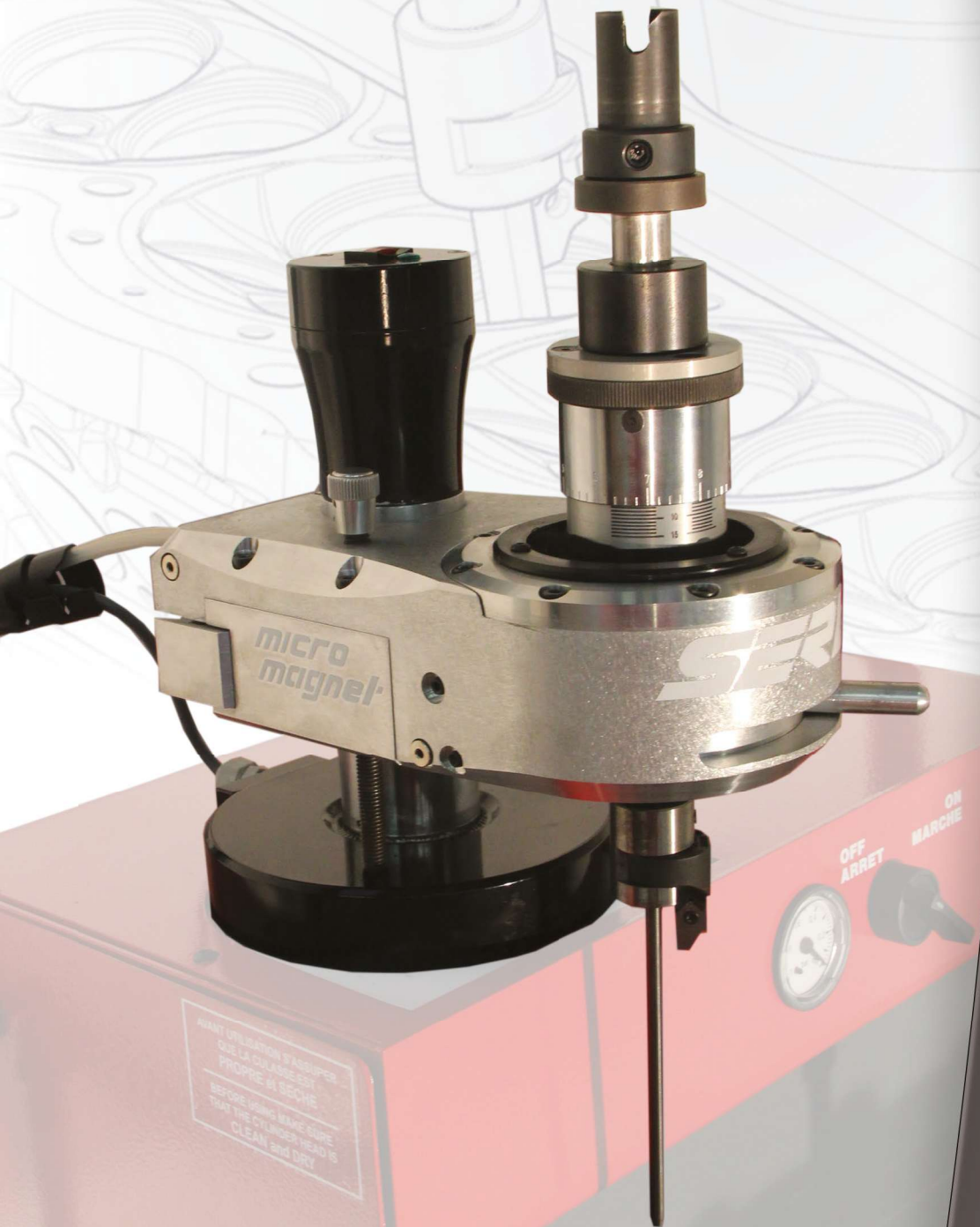

AVANT UTILISATION S'ASSURER QUE LA COLAMBÈRE EST PROPRE ET SÈCHE
BEFORE USING MAKE SURE THAT THE CYLINDER HEAD IS CLEAN and DRY

TECHNICAL FEATURES

Dimensions

Length	mm / inch	253.5/10
Width	mm / inch	135/5.3
Height	mm / inch	208/8.2
Weight	kg / lbs	7/15.4

Spindle

Sphere-cylinder travel (radius)	mm / inch	2.5/0.10
Spindle stroke	mm / inch	15/0.6
Spindle rotation speed	rpm	50 to 150

Machining capacity

mm	16 to 50
inch	0.63 to 2

Connections

Power supply	2.5kVA-230V-AC-1Ph-50/60 Hz
Pneumatic supply	bar / psi 6/87
Max. air flow	l/mn -CFM 40/1.5



TOOLING



MM type pilot
 Ø 9.52 mm - 3/8" shank
 Ø 3.5 to Ø 14 mm
 160 mm



DUAL AIR CUSHION

horizontal air cushion

spherical air cushion

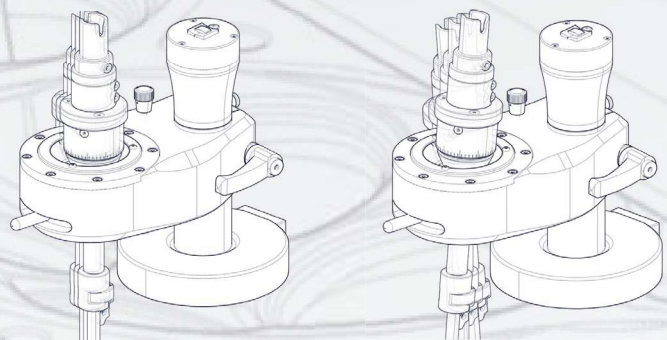

MACHINES SERDI S.A.

23, avenue des vieux moulins
 B.P. 380
 74012 Annecy Cedex
 France

☎ 00 33 4 50 65 63 00
 Fax: 00 33 4 50 52 99 92
 www.serdi.com
 Email: export@serdi.com

SERDI CORP.

301 Cayuga Dr Suite C
 Mooresville
 North Carolina 28117
 USA

☎ (770) 493 82 20
 customerservice@serdi-usa.com

Your distributor:



fijntechniek fijnvaart b.v.
 Machines voor motoren revisie,
 honen en ultrasoonreiniging

Service makes the difference!

Blaaksedijk 30 | 4793 RN Fijnvaart | Nederland
 tel. +31 (0)168 46 44 61 info@ftf.nl www.ftfmachines.com